

# KYOOKA

KYOOKA Co.,Ltd

1-22-13 Higashiyama Meguro-ku

Tokyo 153-0043 Japan

Tel : (81)3-5724-6051

[www.kyooka.co.jp](http://www.kyooka.co.jp)

## Digital Thickness Gauge

Realizes overwhelming shortening of gap measurement time

for a wide area of measurement points.

---



隙  
隙

間測定器

測定器

# Digital Thickness Gauge

## Measuring gap with narrow and depth

Gap measuring system developed so that measurement of a deep gap which was difficult to measure up to now can be done quickly.

It was usually difficult to measure a gap with a depth relative to the entrance of the gap.

This Gap measuring system can quickly and accurately measure gap with narrow and depth.

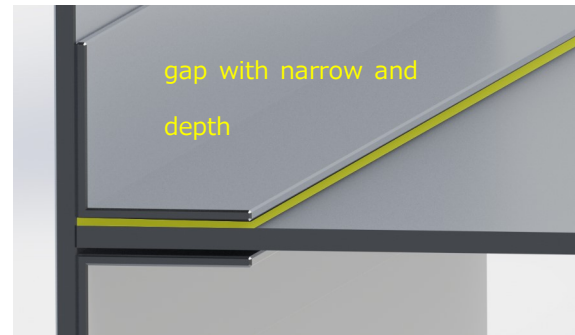

## Measuring probe with a 0.2mm thickness

Insert the measuring probe of 0.2 mm and measure the gap.

Corresponds to measurement of clearance from 0.3 mm to 3.0 mm.

Corresponding gap width and probe length can correspond individually according to request.



## Measuring probe area at once

It can be measured instantaneously at probe area by inserting it into the gap.

There are 6 measurement points on the probe, and measurements are made at once, and locations other than the measured 6 points are supplemented by calculation.

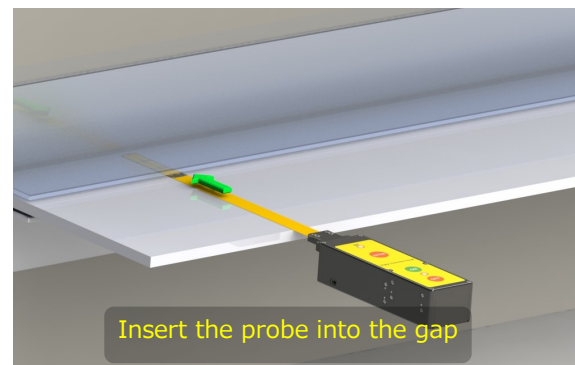

## Usability

Inserting the measuring probe into the gap, then can measure one after another by pushing the measurement button.

Measurement data is stored internally and can be output as a file.

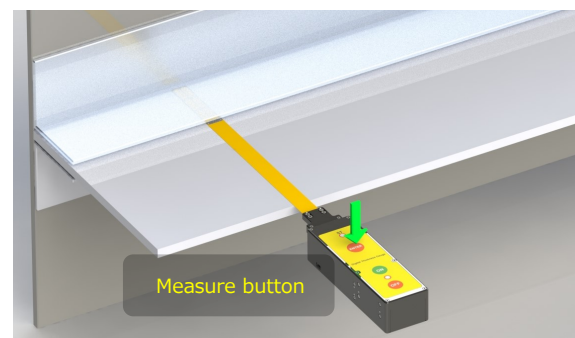

# Digital Thickness Gauge

---

## User interface

Display the measurement results by the tablet.

Tablet is wire-less, so operator can work while confirming the result .

This system output it as CSV, point group data, STL format, so it can be imported into 3D-CAD.

Creating system by specification according based on customer's request.

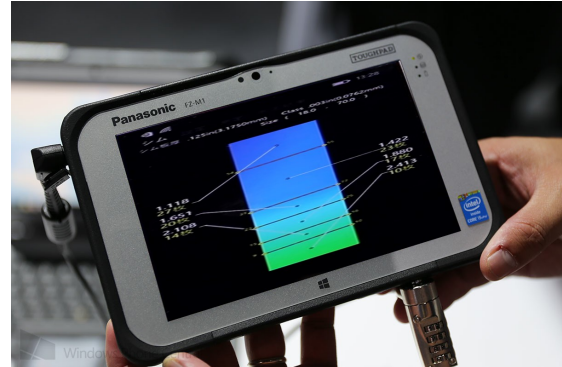

## Elements

The measurement calculates the distance with the object and a displacement of the capacitance of the probe.

The capacitance is proportional to the area of the electrode and inversely proportional to the distance between the electrode and the object.

Since the area of the electrode is known beforehand, the distance between the object and the electrode can be obtained by measuring the capacitance.

Measure this on both sides of the probe and use it as a gap.

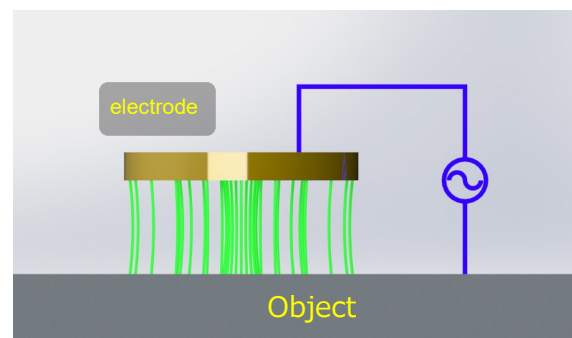
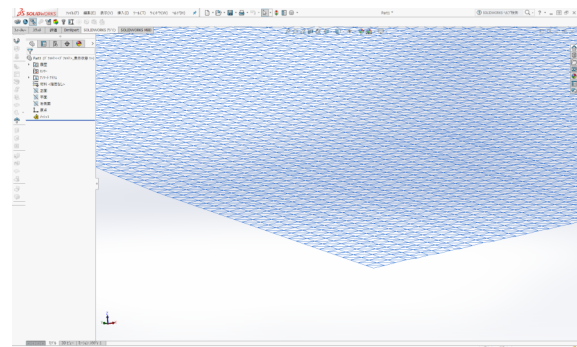

## Customizing

The measurement range of the standard probe is 3.0mm from 0.3mm.

But it is possible to fabricate the probe's range to your requirement.

# Digital Thickness Gauge

---

## Measurement accuracy

---

Measurement accuracy is  $\pm 0.6\%$  FS.

It is  $\pm 0.018$  mm for measurement range up to 3.0 mm.

## Size (mm)

---

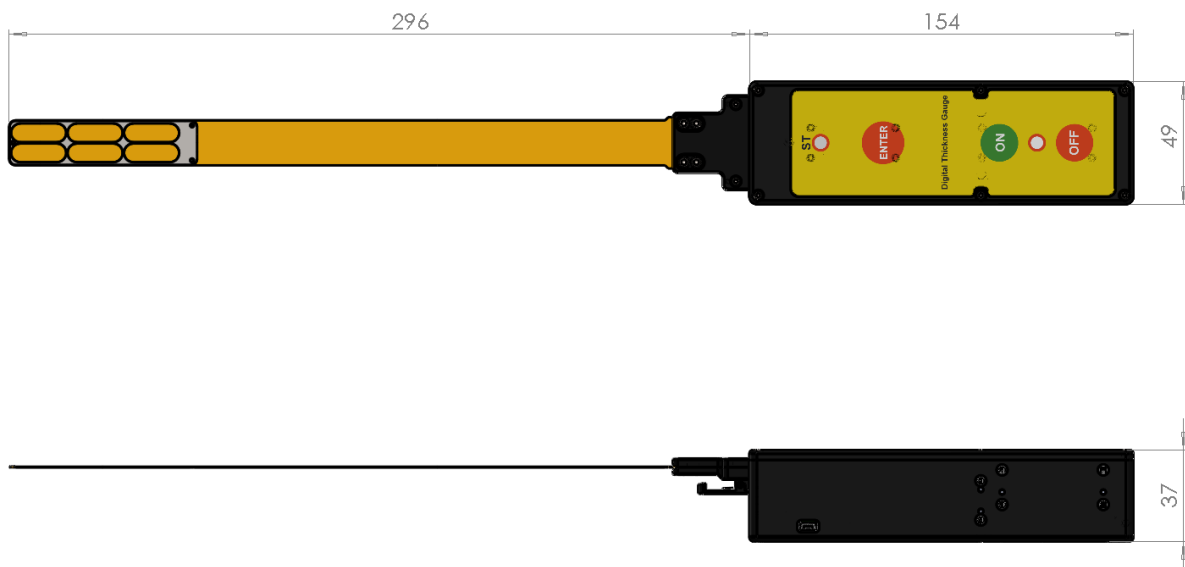

Net Weight

Tester body : 360g